



Hopper Dryer

SHD-300U



Refer carefully to this manual before operation.

SHD-U Series

■ Coding Principle

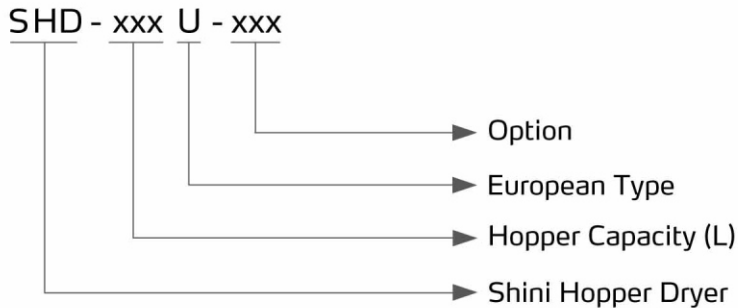

SHD-80U-HD
& Floor Stand (optional)

■ Features

- Adopt P.I.D temperature control and LCD display, with RS485 communication function.
- Overheat protection to ensure reliable operation.
- 7-day automatic start/stop timer to improve energy saving.
- Unique design of down-blow air pipe can spread hot air evenly, keeping plastics dry and temperature stable to raise drying efficiency.
- SHD-80U and models above have material clearance door to make cleaning more convenient and effective.
- SHD-450U and models below are equipped with stainless steel lining aluminium base. SHD-600U~750U is equipped with aluminium magnetic base. SHD-900U and model above are equipped with manual butterfly valve.
- For SHD-900U models and above, floor stand is standard equipment.

■ Working Principle

Air blown out of drying blower becomes high temperature drying air after being heated. Through particular down-blowing air pipe, hot air can be equably dispersed in the material storage tank. Hot air recycler can be equipped to filter and recycle the air from the air outlet and form a closed loop circle.

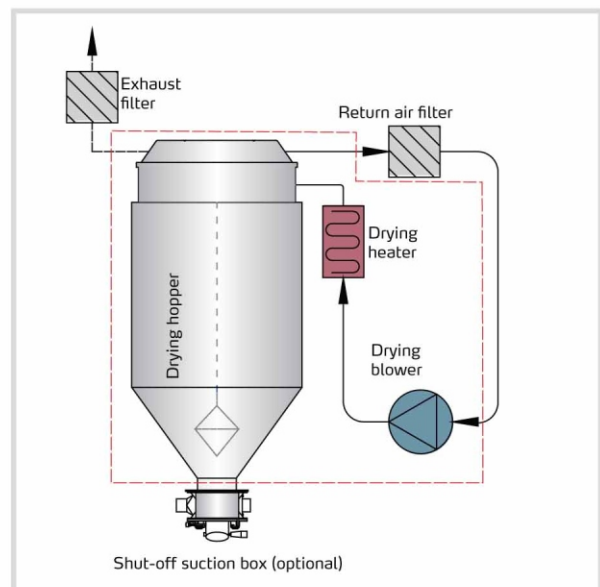

■ Application

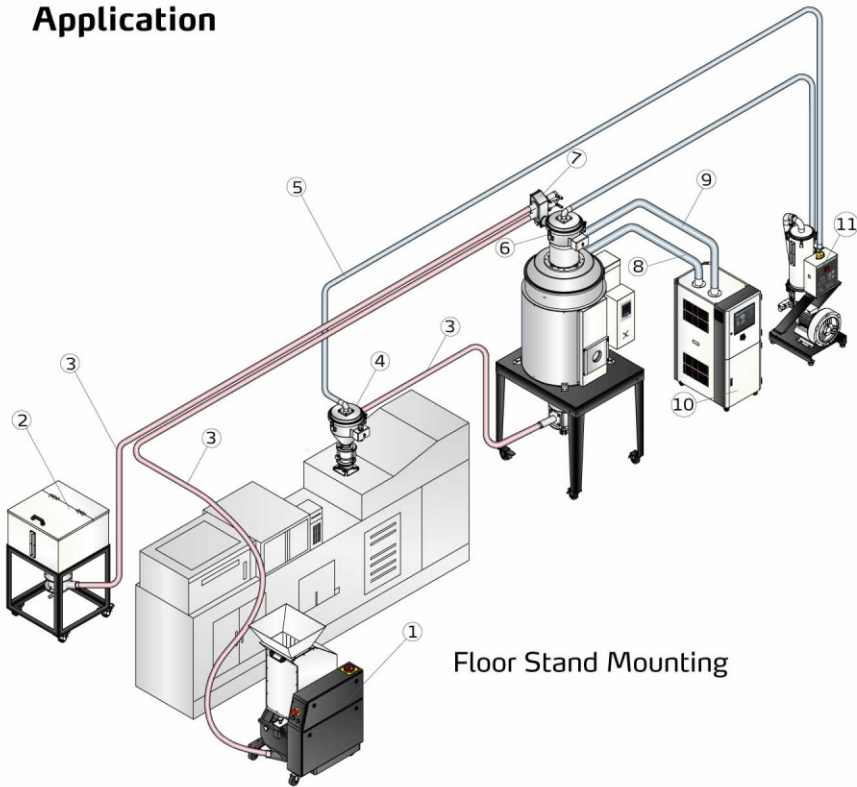

- 1. Low-speed granulator
- 2. Material tank
- 3. Material pipe
- 4. Photosensor hopper
- 5. Vacuum pipe
- 6. Vacuum hopper
- 7. Proportional valve

Floor Stand Mounting

- 8. Dehumidifying air
- 9. Return air
- 10. Honeycomb dehumidifier
- 11. Separate auto loader
- 12. Auto loader
- 13. Hopper dryer

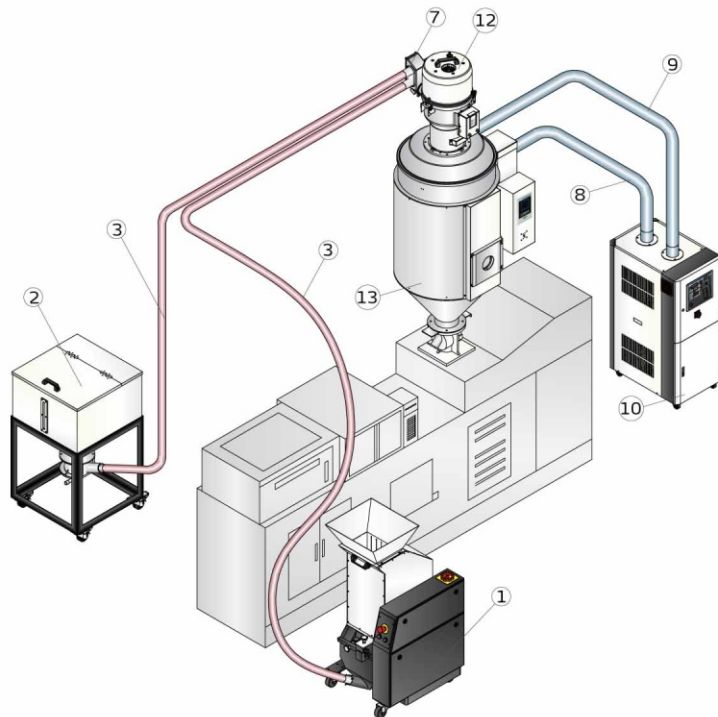

Direct Mounting

SHD-U Series

Outline Drawings

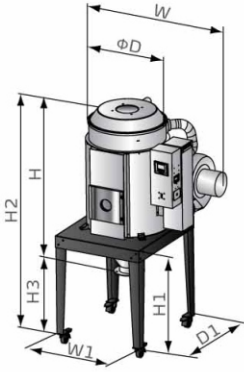

SHD-20U-750U

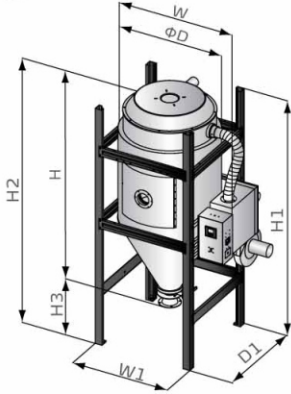

SHD-900U-1200U

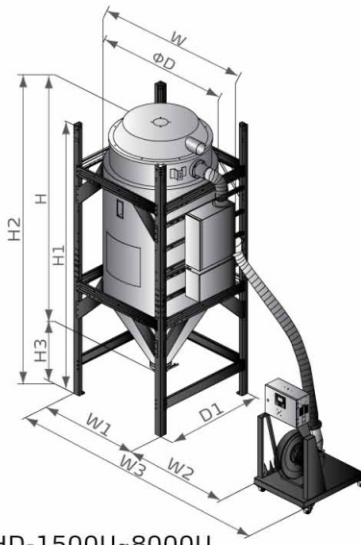

SHD-1500U-8000U

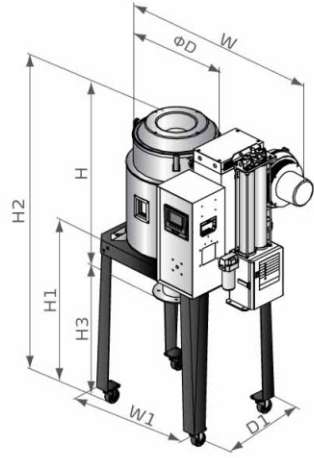

SHD-U-HD

Specifications

Model	SHD-20U	40U (-HD)	80U (-HD)	120U (-HD)	230U (-HD)	160U	230U	300U	450U	600U	750U	900U	1200U	1500U	2000U	2500U	3000U	3500U	4000U	5000U	6000U	7000U	8000U		
Heater(kW)	2.2	3	3.9	3.9	6	6	6	12	12	18	18	18	24	32	32	58	58	64	64	80	96	112	128		
Blower(kW)	0.05	0.12	0.12	0.12	0.12	0.12	0.12	0.18	0.18	0.55	0.55	0.55	1.1	3	3	5.5	5.5	7.5	7.5	11	15	18.5	22		
Hopper Capacity	L	20	40	80	120	230	160	230	300	450	600	750	900	1200	1500	2000	2500	3000	3500	4000	5000	6000	7000	8000	
	gal	5.3	10.6	21	31.7	60.8	42.3	60.8	79.3	118.9	158.5	198	237.8	317	396	528	660	793	925	1057	1321	1585	1849	2113	
Dimension	H	mm	680	770	940	1190	1470	1200	1470	1430	1840	1830	2080	2330	2765	3095	3685	3735	4135	4535	4180	4775	4520	5460	6030
		Inch	26.8	30.3	37	46.9	57.9	47.2	57.9	56.3	72.4	72	81.9	91.7	109	122	145	147	163	179	165	188	178	215	237
	W	mm	575	770	860	860	875	875	875	1005	1005	1250	1250	1410	1410	1640	1542	1798	1798	1798	2010	2010	2250	2250	2250
		Inch	22.6	30.3	33.9	33.9	34.4	34.4	34.4	39.6	39.6	49.2	49.2	55.5	55.5	64.6	60.7	70.8	70.8	70.8	79	79	88.6	88.6	88.6
	D	mm	325	394	472	472	575	575	575	695	695	915	915	1050	1050	1250	1250	1400	1400	1400	1600	1600	1800	1800	1800
		Inch	12.8	15.5	18.6	18.6	22.6	22.6	22.6	27.4	27.4	36	36	41.3	41.3	49.2	49.2	55	55	55	63	63	71	71	71
Floor Stand	H1	mm	790	790	840	840	920	920	920	970	970	1130	1130	2760	3190	3470	3870	4000	4400	4800	4550	5150	4870	5805	5620
		Inch	31	31	33	33	36.2	36.2	36.2	38	38	44.5	44.5	109	126	137	152	157	173	189	179	203	192	228	221
	W1	mm	450	580	730	730	652	652	652	790	790	1000	1000	1130	1145	1340	1340	1482	1482	1482	1680	1680	1930	1930	1930
		Inch	17.7	22.8	28.7	28.7	25.7	25.7	25.7	31	31	39.4	39.4	44.5	45	52.8	52.8	58.3	58.3	58.3	66	66	76	76	76
	W2	mm	-	-	-	-	-	-	-	-	-	-	-	-	400	400	400	400	400	400	400	400	400	400	400
		Inch	-	-	-	-	-	-	-	-	-	-	-	-	15.7	15.7	15.7	15.7	15.7	15.7	15.7	15.7	15.7	15.7	15.7
	W3	mm	-	-	-	-	-	-	-	-	-	-	-	-	2000	2000	2260	2260	2260	2260	2460	2530	2780	2830	2830
		Inch	-	-	-	-	-	-	-	-	-	-	-	-	78.7	78.7	89	89	89	89	96.9	99.6	109.4	111.4	111.4
	D1	mm	550	450	560	560	795	795	795	930	930	1200	1200	1130	1145	1340	1340	1482	1482	1482	1680	1680	1930	1930	1930
		Inch	21.7	17.7	22	22	31.3	31.3	31.3	36.6	36.6	47.2	47.2	44.4	45	52.8	52.8	58.3	58.3	58.3	66	66	76	76	76
H2	mm	1260	1300	1480	1740	2105	1825	2105	2085	2435	2470	2780	2765	3190	3470	3870	4000	4400	4800	4635	5235	4923	5840	6425	
	Inch	49.6	51	58.3	68.5	82.9	71.9	82.9	82	96	97.2	109	108.8	125.6	136.6	152.4	157.5	173	189	182.5	206	193.8	230	253	
Air Inlet (inch)	2		2.5			3			4			5			6			8			10				
Air Outlet (inch)	1.5		2			2.5			4			5			6			8			10				
Net Weight	kg	40	70	85	100	115	90	100	130	160	200	220	410	560	685	770	800	900	1010	1160	1390	1530	1735	1820	
	lb	88	154	187	220	220	198	220	287	353	441	485	904	1235	1510	1698	1764	1984	2227	2557	3064	3373	3825	4012	

Notes: 1) Power: 3Φ, 230/400/460/575VAC, 50/60Hz.

We reserve the right to change specifications without prior notice.